

# ROSTA Anti-vibration Mountings





## Technology

With a **relatively hard** machine support or mounting, the amplitude of the installed equipment is minimal, but the resulting isolation efficiency is much less than with a more resilient mounting. Although technically the isolation efficiency of a **soft** mounting is very high, it impairs the machine stability and can lead to uncontrolled operation of the installation (example: distorted frames on production machines). Hence, for the machine type in question, an ideal compromise must be sought between the level of the isolation efficiency and permissible spring deflection. As a general rule the mountings of machine tools, machining centers etc. should be **hard** whilst those for equipment such as compressors, generators and pumps etc. should be relatively **soft**. Rubber as an elastic medium is probably the most universal material used for vibrational damping.

Its special properties render it particularly suitable for damping and springing elements. Rubber elements can accept considerable overloads for a short time without suffering any damage. In contrast to steel springs, under dynamic loading, rubber elements convert the energy absorbed into heat by internal molecular friction.

This process – known as damping – is continuous and it is always required whenever resonance can occur or shocks have to be reduced quickly.

Two basically different types of rubber loading were made use of in the design of ROSTA anti-vibration mountings:

- pure tensile or pressure loading for the anti-vibration mountings of the types V, ISOCOL and N. These relatively simple elements cover the medium natural frequency band between 15 and 30 Hz.
- loading via lever of pretensioned rubber elements by torsional or flexing motion of the ROSTA rubber suspension units in so-called spring dampers. This system allows the construction of anti-vibration mountings in the low frequency range between 2 and 10 Hz. These are types ESL and AB.

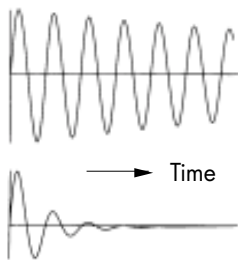

Steel spring  
(no self-damping)

Rubber spring  
(self-damping)

The following survey of the entire product range shows the advantages and applications of the various types. For complex applications and in the case of queries, do not hesitate to get in touch with us – our technical service department is at your disposal.

## Superior Technology

*isolating  
in all directions*

*self adhesive  
on both sides*

**wide  
frequency range**

**efficient  
absorption**

**free standing  
or mounting by bolts**

**unique  
levelling system**

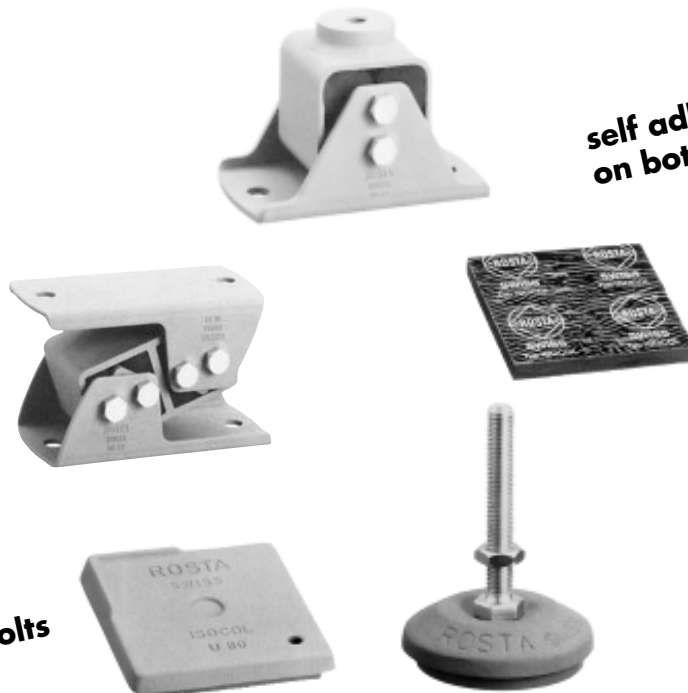



## Technology

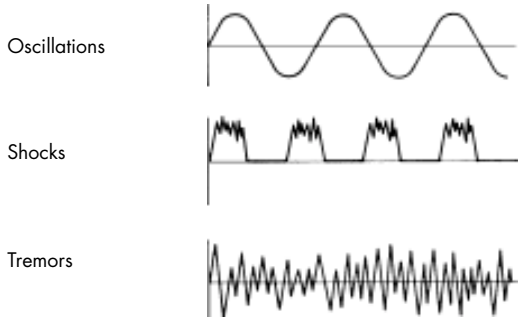

Fig. 1

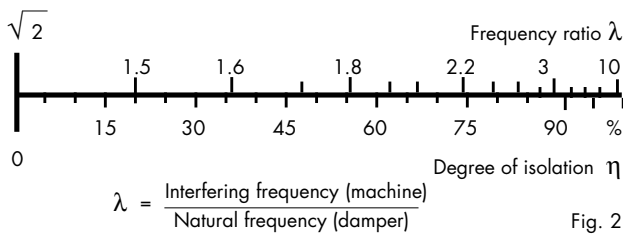

Fig. 2

Acoustic isolation ratio related to steel:	Steel	1 : 1
	Bronze	1 : 1.3
	Cork	1 : 400
	<b>Rubber</b>	<b>1 : 800</b>
	Air	1 : 90000

Fig. 3

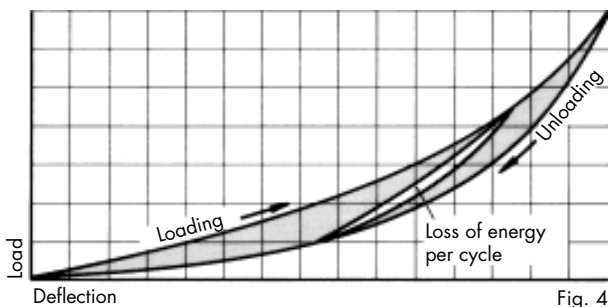

Fig. 4

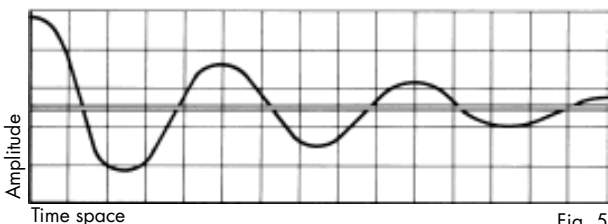

Fig. 5

## Isolation of Vibrations and Solid-borne Noise

There are basically three different forms of vibration, as shown in fig. 1.

The overcritical type of mounting is used for isolating vibrations and tremors, while for isolating shocks the subcritical type of mounting is generally employed.

$$\text{Overcritical: } \frac{\text{Interfering frequency (machine)}}{\text{Natural frequency (damper)}} = > 1$$

$$\text{Subcritical: } \frac{\text{Interfering frequency (machine)}}{\text{Natural frequency (damper)}} = < 1$$

## Mechanical Vibrations

The basic principle of vibration isolation technique is to isolate the source of interference, or the object to be protected, from its surroundings. This is achieved by suitable frequency adaption – the higher the frequency ratio, the higher the degree of isolation. See fig. 2.

## Absorption of Solid-borne Noise

While interference forces are isolated on the basis of vibrational theory, the isolation of sound transmission through solid-borne bodies is governed by the laws of wave mechanics. The isolation efficiency depends on the acoustic stiffness of the contacting materials between machine and structure. The table in fig. 3 shows the absorption efficiency of some material. A steel rubber compound normally offers a highly efficient isolation of the solid-borne noise.

## Damping

In the ROSTA type mounts is damping a function of the internal molecular friction in the rubber material during oscillation and vibration. The resulting energy loss is converted into heat during the vibration process. The area (fig.4) between the loading and unloading curves corresponds to the energy loss or damping in the ROSTA elements.

In practice, the damping characteristic becomes important when the vibrations of an elastically supported machine is passing through the resonance field and an oscillation could build up. The natural isolation properties of the ROSTA anti-vibration mountings limit this build-up to a minimum due to the high energy loss. Vibrations are absorbed as soon as they occur.

The amplitude/time characteristic demonstrates the high efficiency of the rubber damping material.



## Technology

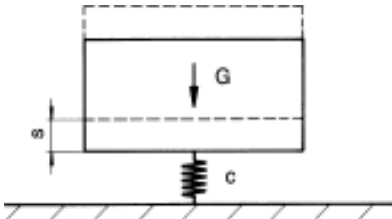

$$\text{Natural frequency } a = \frac{1}{2\pi} \cdot \sqrt{\frac{12 \cdot 32.16}{s \text{ [in.]}}} = \text{Hz}$$

$$\text{or } \frac{60}{2\pi} \cdot \sqrt{\frac{12 \cdot 32.16}{s \text{ [in.]}}} = \text{rpm}$$

Fig. 6

## Natural Frequency of the Vibration Damper

Even simple applications require some elementary knowledge of vibration isolation. An important factor in this connection is the natural frequency of the damper which is measured in rpm or Hz, i.e. the number of oscillations per minute or second which lead to resonance excitation.

The natural frequency  $n_e$  is a function of the spring travel  $s$  (in.) under a load  $G$  (lbs.) and can be calculated from the formula given in fig. 6.

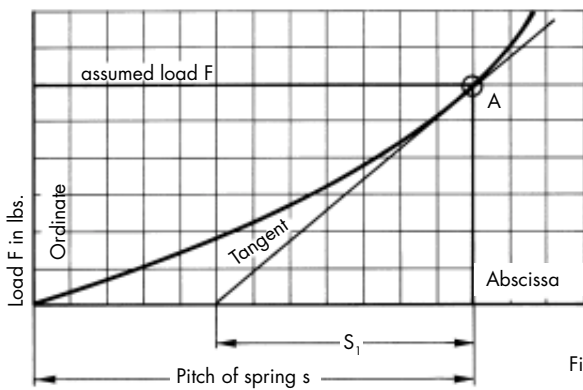

Fig. 7

## Natural Frequency with Parabolic Spring Characteristic

It is only with vibration dampers comprising steel springs that the damper's natural frequency can be derived directly from the measured spring travel according to the formula in fig. 6. Steel springs have a linear characteristic and hence a spring constant. But they have no damping and are only suitable for pure swing mountings.

All other damping materials such as rubber, cork etc., are deformed under load and the effective measured spring travel is greater than the actual resulting natural frequency. Rubber springs have a slightly parabolic characteristic and the natural frequency resulting from the applied load is therefore essentially higher than the calculated value in conformity with the spring travel (fig. 7:  $s_1$  determines the frequency). The following catalogue frequency values are measured and derived from the  $s_1$  spring travel.

Hence the natural frequency values must lie outside the resonance field. An undesirable build-up of vibrations is likely to occur wherever the exciting frequency  $n_{err}$  and natural frequency  $n_e$  are the same.

$\lambda < 1$ : damping is not exactly definable and solid-borne noise isolation is reduced

$\lambda = 1$ : oscillation build-up, peak values depending on self-damping  $D$  within the resonance field

$\lambda > \sqrt{2}$ : also efficient solid-borne noise isolation

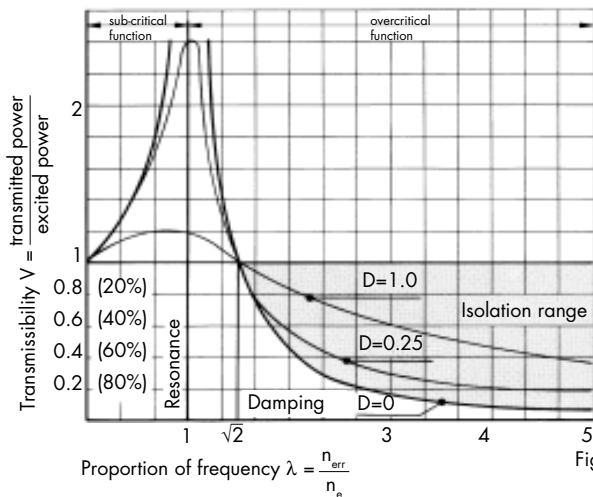

Fig. 8

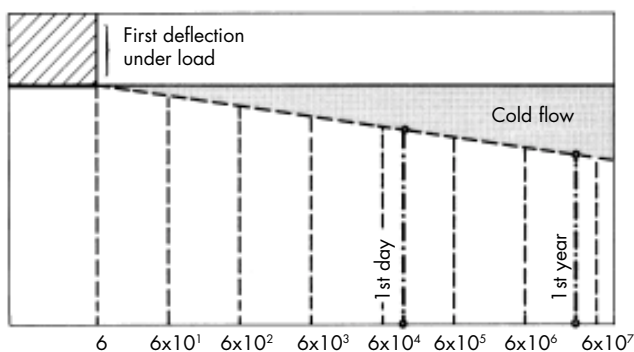

Fig. 9

## Cold Flow

During the course of time, all elastic materials deform more or less permanently under load, which becomes apparent by a slight increase in deflection and cold flow. This cold flow exhibits a linear characteristic on a logarithmic time base. The diagram in fig. 9 shows that more than half of the total cold flow occurring in one year has taken place after loading for one day. The max. setting of ROSTA anti-vibration mountings is approx. +10% of the nominal spring travel according to the catalogue.



## Technology

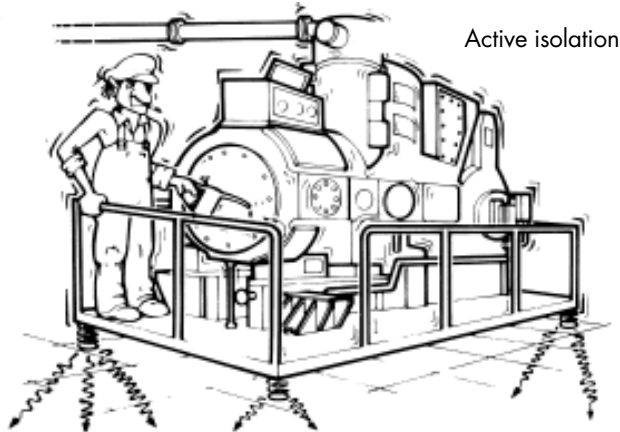

Fig. 10

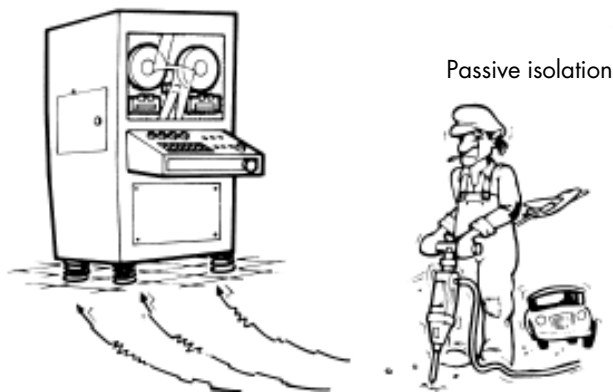

Fig. 11

## Active and Passive Isolation

In practice, elastic intermediate supports or mountings are installed for two different reasons:

### Practical Considerations

The use vibration damping machine mountings and supports permits continuously **flexible** installation of a machine line. Conventional floor anchorages can be almost totally dispensed with and the machines rapidly and simply converted to new production sequences. Furthermore, the normally standard integrated levelling facilities are a simple way to compensate for uneven floor surfaces.

### Protective Considerations

Personnel, environment, building structure and the machines themselves are efficiently protected by the **vibration compensating** machine supports. Vibrations and shocks are considerably reduced and the working environment improved.

**Active or direct isolation** signifies the damping of the vibrations and shocks from an operating machine, i.e. to prevent vibrations being transferred to foundation, adjacent rooms, building etc. To be taken into account in each case here are the interfering frequency, the machine structure and its site. This is the most frequent type of vibration isolation and occurs in almost all factories or households.

**Passive or indirect isolation** signifies the shielding of sensitive equipment such as weighing and measuring instruments, laboratory appliances etc. from vibrations and shocks. Here the technical requirements can be highly dependent on the environment since interference is often external in origin; from the street, railways or large building sites. The assistance of the specialist engineer is frequently necessary to define this spectrum.

## Defining the Supporting Forces

a) Position of ROSTA anti-vibration mountings on/under the machine frame

Install all elements so that the loading or spring travel is uniform. Whenever – as so often in practise – asymmetric center of gravity circumstances and hence differing loads and spring travels are encountered, the supporting forces can be determined according to fig. 12. In such cases, differences in spring travel are to be equalized with the aid of spacer plates.

$$\text{Load on point A} = S \cdot \frac{b}{a} \cdot \frac{d-c}{d}$$

$$B = S \cdot \frac{a-b}{a} \cdot \frac{d-c}{d}$$

$$C = S \cdot \frac{b}{a} \cdot \frac{c}{d}$$

$$D = S \cdot \frac{a-b}{a} \cdot \frac{c}{d} \quad 75$$

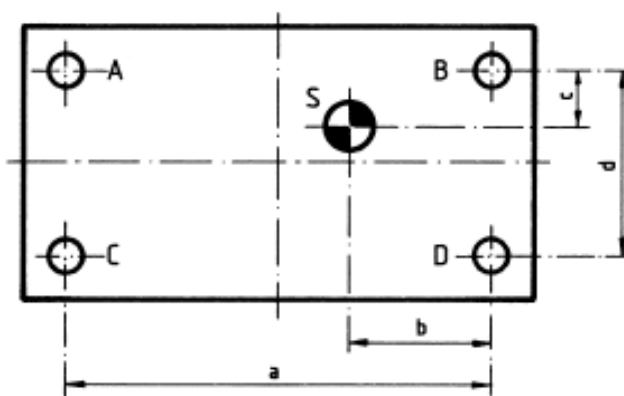

A, B, C, D Mounting points of anti-vibration mountings  
S Center of gravity

Fig. 12



## Product Range

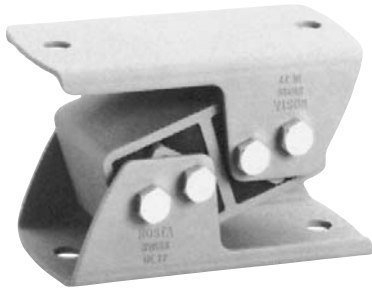

### ROSTA Anti-vibration Mounting Type ESL

Page 77

ROSTA anti-vibration mountings type ESL are intended for the absorption of medium and low frequency vibrations and are designed to accept compression, tension and shear loading as well as combined loadings. They can be installed in any desired position and are also ideal for ceiling and wall mounting. Due to the mechanically secured principle of the anti-vibration mountings type ESL no tearing off is possible. These elements are maintenance-free, insensitive to water and dirt and suitable for temperatures from  $-40^{\circ}$  to  $+180^{\circ}$  F. The housing and core of the elements up to size 45 are made of light alloy with steel brackets. The housing of size 50 is made of GGG 40. All elements are paint-finished.

### ROSTA Anti-vibration Mounting Type V

Page 78

ROSTA anti-vibration mountings type V are multi-directional dampers and are designed to accept compression, tension and shear loading as well as combined loadings. They can be installed in any desired position and are also ideal for ceiling and wall mounting. Due to the mechanically secured principle of the anti-vibration mountings type V no tearing off is possible. These elements are maintenance-free, insensitive to water and dirt and suitable for temperatures from  $-40^{\circ}$  to  $+180^{\circ}$  F. The core is made of light alloy, the outer housing and brackets of steel. All elements are paint-finished.



## Anti-vibration Mounting

## Type ESL

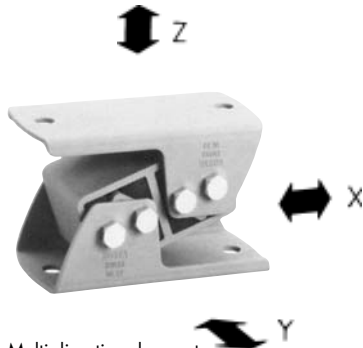

Multi-directional mount for compression, tension and shear loading

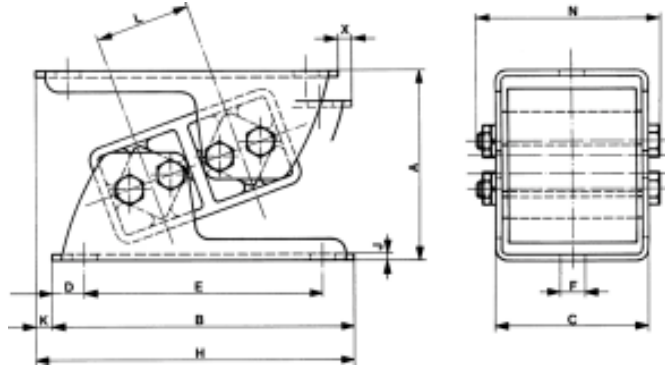

UPC #	Type	Load G in lbs.	A un-loaded	A max. load	B	C	D	E	ØF	H	J	K	L	N	X max.	Weight in lbs.
25 214	ESL 15	- 89.92	2.13	1.73	3.35	1.93	0.39	2.56	0.28	3.56	0.08	0.22	1.00	2.30	0.06	0.79
25 215	ESL 18	67.44 - 269.77	2.56	2.05	4.13	2.36	0.49	3.15	0.37	4.35	0.10	0.22	1.22	2.72	0.07	1.37
25 216	ESL 27	224.81 - 449.62	3.46	2.83	5.51	2.80	0.59	4.33	0.45	5.83	0.12	0.31	1.73	3.36	0.10	2.82
25 217	ESL 38	404.66 - 786.84	4.61	3.66	6.89	3.86	0.69	5.51	0.55	7.17	0.16	0.28	2.36	4.61	0.14	7.50
25 218	ESL 45	719.39 - 1348.86	5.63	4.53	8.66	4.72	0.98	6.69	0.71	9.23	0.20	0.57	2.87	5.43	0.17	11.57
25 219	ESL 50	1236.46 - 2023.29	6.50	5.28	8.66	5.59	0.98	6.89	0.71	9.45	0.24	0.59	3.09	6.42	0.19	22.05

The max. load on X ÷ X axes is the double value from Z ÷ Z axes.  
The max. load on Y ÷ Y axes is 20% from Z ÷ Z axes.

### Applications

For active and passive isolation of vibrations and maximum damping of solid-borne noise transmission in: weighbridges and scales, measuring systems, control equipment, rotary machinery such as compressors, refrigerating systems, blowers, pumps, mills, mixers, shock-absorbent buffers, etc.

For installation guidelines see

The elements must generally be installed in the same direction

Fig. a) Dynamic forces longitudinal

Fig. b) Dynamic forces lateral

Fig. c) Wall mounting

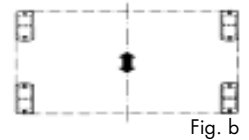

Fig. b

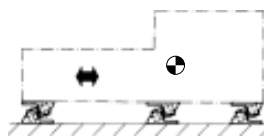

Fig. a

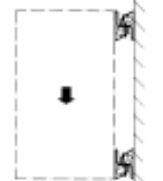
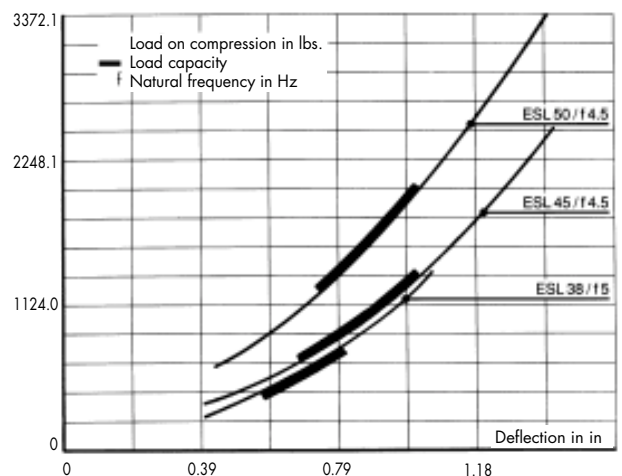
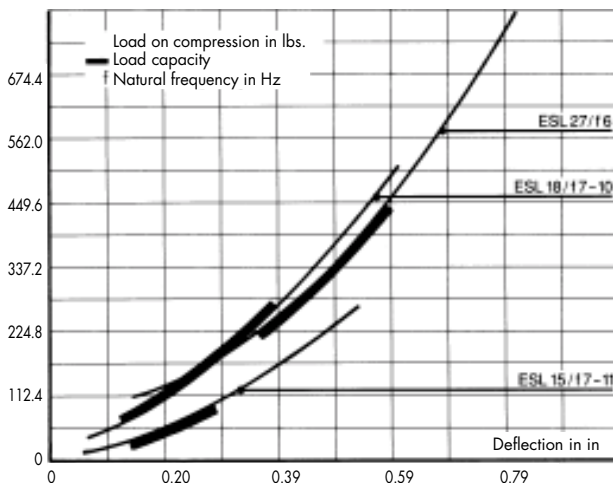

Fig. c





## Anti-vibration Mounting

## Type V

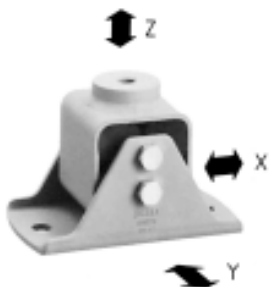

Type V 15 – 45

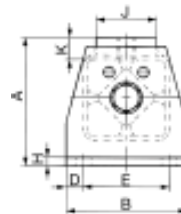
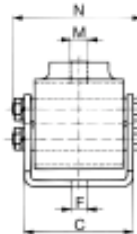
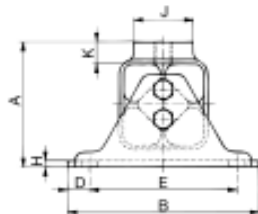

Type V 50

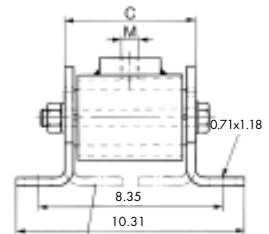

Alternativ mounting position

Multi-directional mount for compression, tension and shear loading

UPC #	Type	Load G in lbs.	A	B	C	D	E	ØF	M	N	H	ØJ	K	Weight in lbs.
53 373	V 15	- 179.85	1.93	3.15	2.01	0.49	2.17	0.37	M 10	2.30	0.12	0.79	0.39	0.66
57 653	V 18	134.89 – 359.70	2.60	3.94	2.44	0.49	2.95	0.37	M 10	2.91	0.14	1.18	0.51	1.54
57 654	V 27	292.25 – 674.43	3.31	5.12	2.87	0.59	3.94	0.45	M 12	3.36	0.16	1.57	0.57	2.76
57 655	V 38	584.51 – 1124.05	4.13	6.10	3.94	0.69	4.72	0.55	M 16	4.61	0.20	1.77	0.69	5.40
57 656	V 45	1011.65 – 1798.48	5.00	7.48	4.80	0.98	5.51	0.71	M 20	5.83	0.24	2.36	0.89	10.23
63 661	V 50	1348.86 – 2697.72	5.91	5.51	5.91	0.79	3.94		M 20	10.31	0.39	2.76	0.98	16.45

The max. load on Y ÷ Y axes is 10% from Z ÷ Z and X ÷ X axes.  
Momentary shock loads of 2.5 g in Z ÷ Z and X ÷ X axes are admissible.

### Applications

For active and passive isolation of vibrations and damping of solid-borne noise transmission in crushing plants, compressors, blowers, pumps, rotary converters, generators, mills, crane track supports, etc.

For installation guidelines see

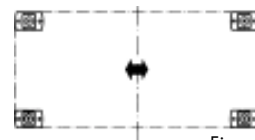

Fig. a

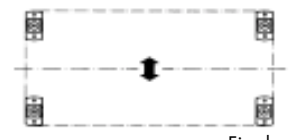

Fig. b

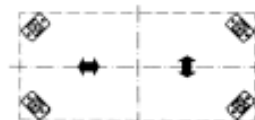
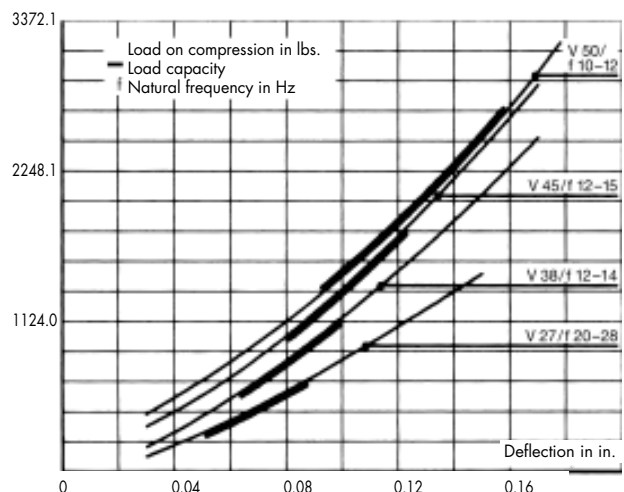
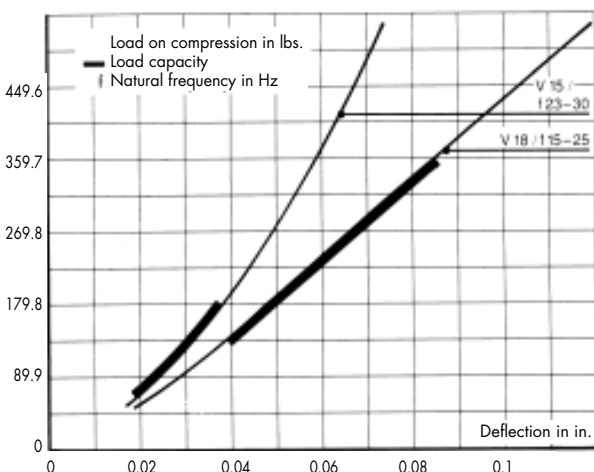

Fig. c

- Fig. a) Dynamic forces longitudinal
- Fig. b) Dynamic forces lateral
- Fig. c) Dynamic forces undeterminant







## Installations

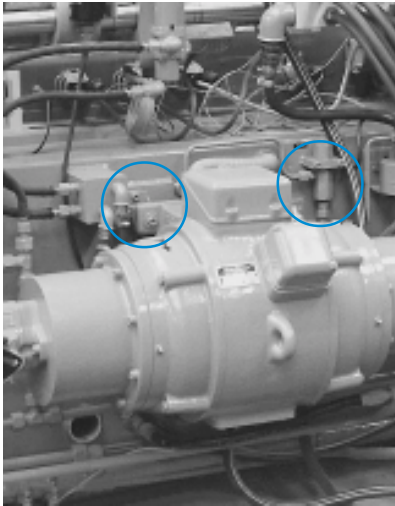

Hydraulic pump on type V (wall fixation)



Chain feeder on type V

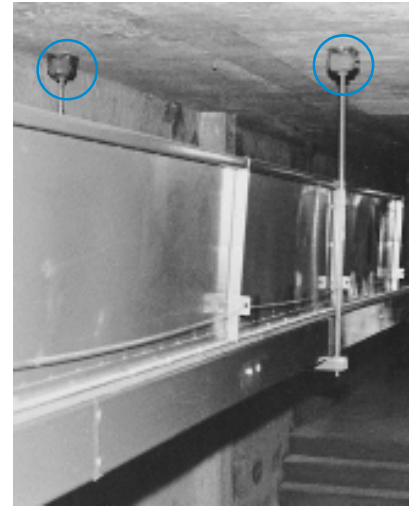

Belt conveyor suspension with type V (ceiling fixation)

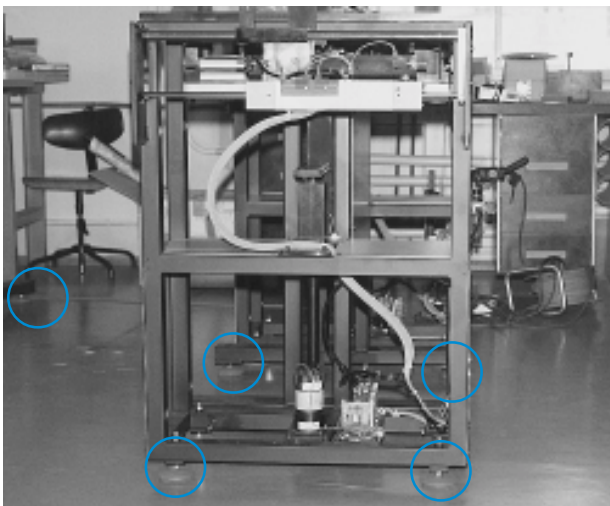

Assembling robot on type N

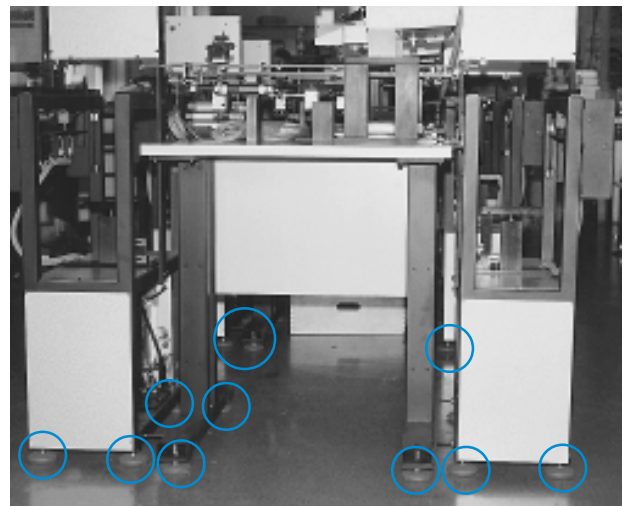

Assembling line on type N

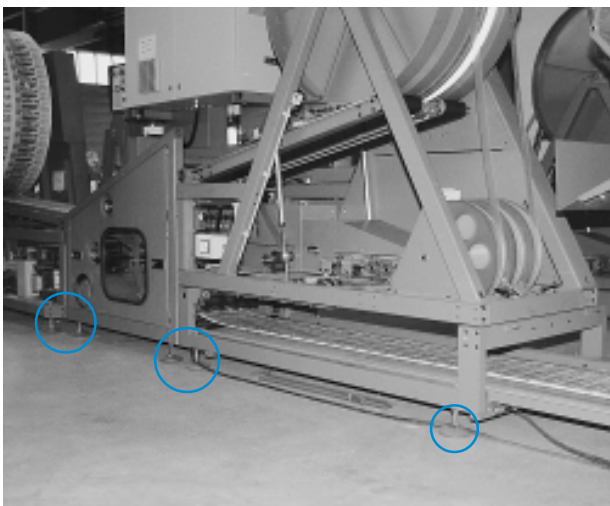

80 Continuous newspaper folding machine on type N

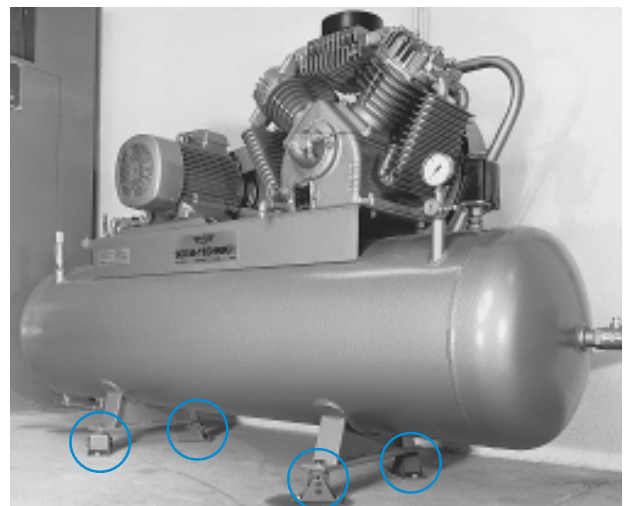

Air compressor on type V